

# Lombard

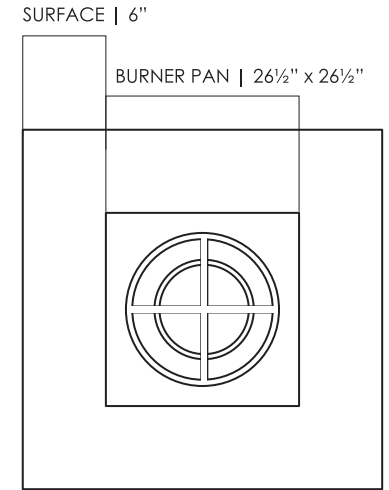

## SPECIFICATIONS

Width	40"
Height	18"
Surface	6"
Burner Pan Size	26½" / 65,000 BTU
Weight	280 lbs.
Fuel Source	LP or NG
Ignition	Electric Ignition
Materials	Glass fiber reinforced cement

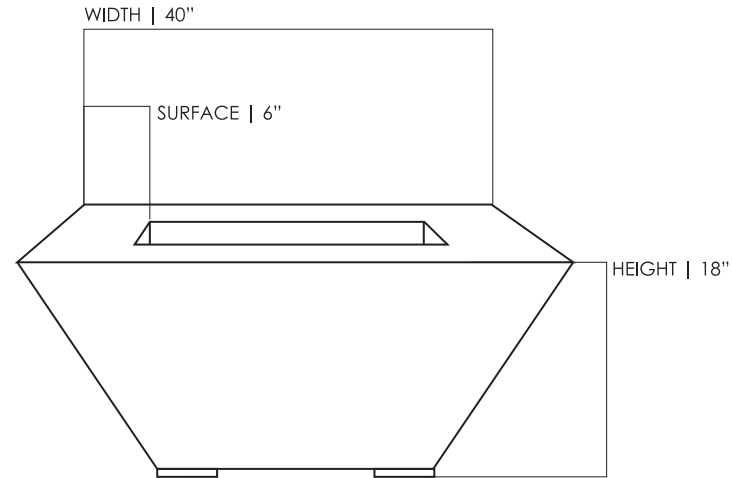

# Embarcadero



## SPECIFICATIONS

Diameter	48"
Height	15"
Surface	7"
Burner Plate Size	25" / 65,000 BTU
Burner Size	18" Double Ring Burner
Weight	225 lbs.
Fuel Source	LP or NG
Ignition	Key Valve
Materials	Glass fiber reinforced cement

